

# CAP-F-N

Multi Nozzle Diffuser



# Table of Contents

<a href="#"><u>Description</u></a>	3
<a href="#"><u>Setup Possibilities</u></a>	5
<a href="#"><u>Dimensions</u></a>	6
<a href="#"><u>Ordering Codes</u></a>	7
<a href="#"><u>Accessories</u></a>	8
<a href="#"><u>Quick Selection</u></a>	10
<a href="#"><u>Technical Parameters</u></a>	11
<a href="#"><u>Installation</u></a>	17
<a href="#"><u>Transport, Storage and Operation</u></a>	28
<a href="#"><u>Supplement</u></a>	29



## Description

CAP-F-N is a multi-nozzle diffuser with a backing box, mainly intended for air supply in comfort ventilation systems for offices, shops, medical rooms, school classrooms, etc., installed in T-bar false ceiling.

### Highlights

- Versatile adjustability of air discharge patterns
- Excellent air induction and mixing even with small air flow volumes, fit for VAV ventilation
- High air flow capacity with low sound level and moderate pressure drop
- Compact design

## Design

The CAP-F-N body is made from galvanized steel, composed of the backing box with a vertically oriented rubber gasket sealed circular connection and diffuser plate with polymer nozzles, attached by spring clips. The nozzles can be rotated by 360° in the plane of the diffuser plate. The proper directional adjustment of the individual nozzles results in the desired air discharge pattern. The backing box frame has dimensions to fit into the T-bar false ceiling either with raster 600 mm or 625 mm.

Product Parts

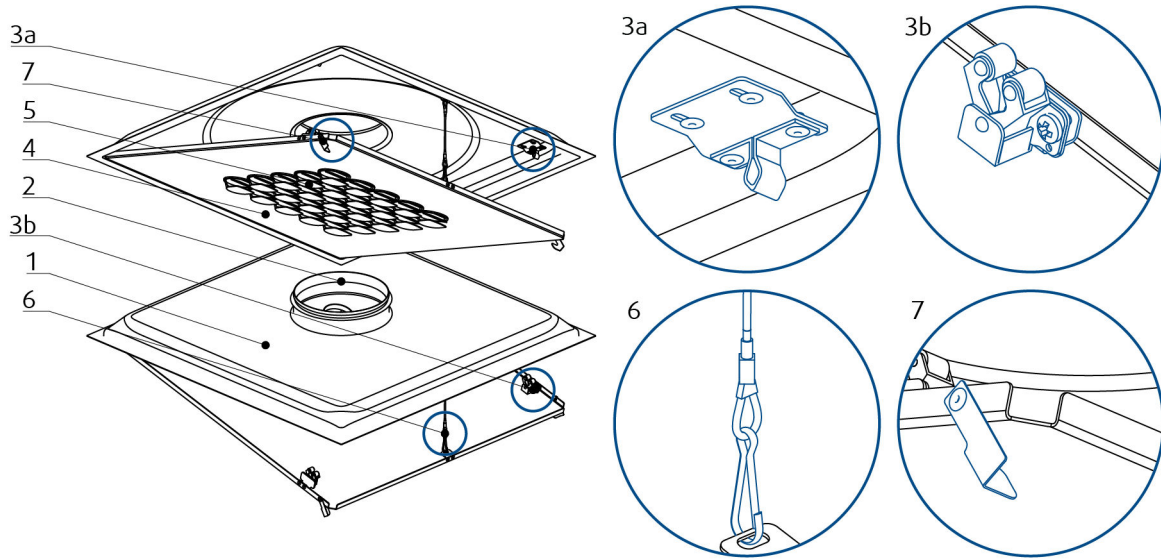

Legend

- 1 Backing box
- 2 Connection with rubber gasket
- 3 Spring clips for diffuser plate fixing (inside the backing box)
- 4 Diffuser plate
- 5 Nozzles
- 6 Safety cable (inside the backing box)
- 7 Commissioning tubes pull cut-outs

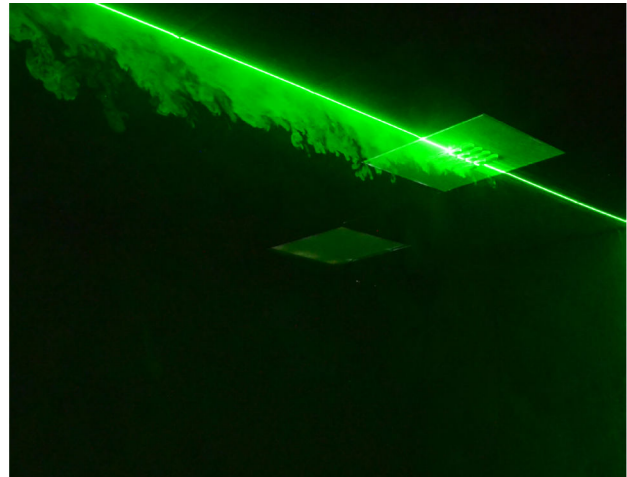
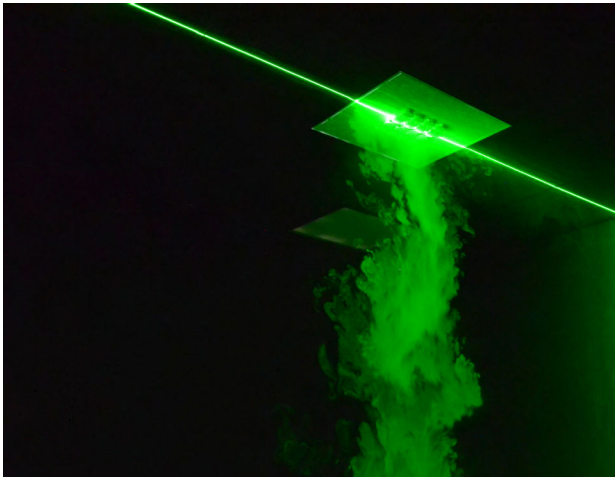

Air flow visualisation

# Setup Possibilities

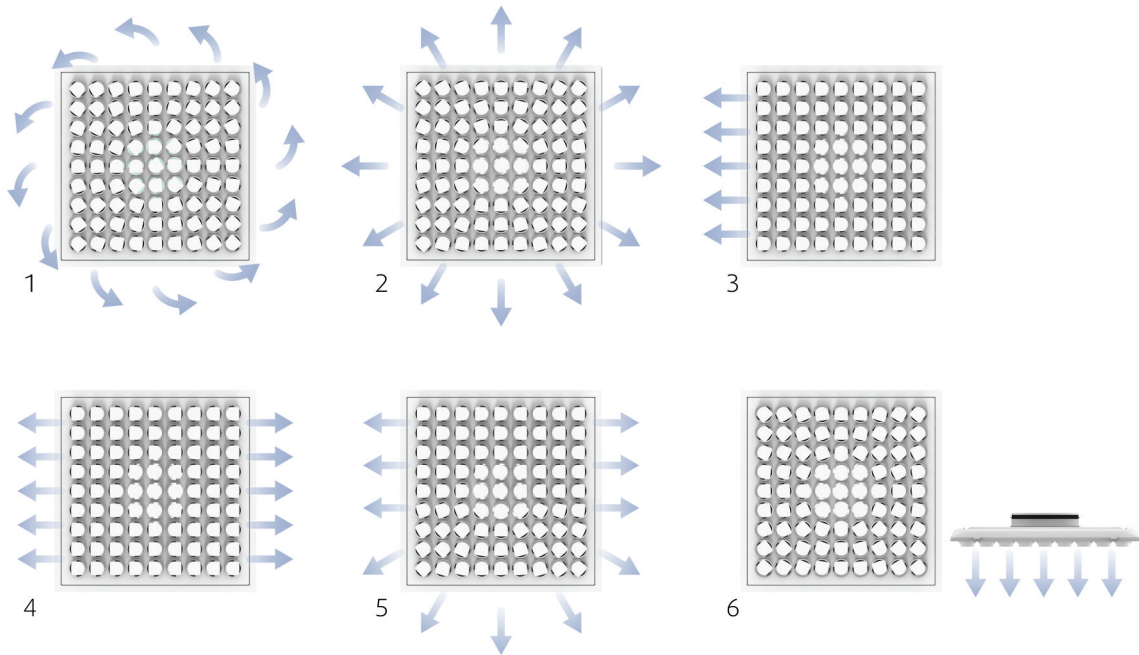

Nozzle adjustments and resulting air flow pattern

## Legend

- 1 Tangential horizontal swirl discharge
- 2 Radial horizontal omnidirectional discharge
- 3 Horizontal discharge, single direction
- 4 Horizontal discharge, 2 directions
- 5 Horizontal discharge, 3 directions
- 6 Vertical discharge

# Dimensions

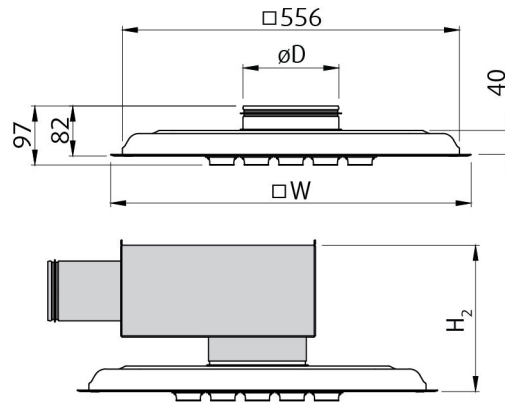

	$W$	$\varnothing D$	$H_2$	$m$
	mm			kg
CAP-F-N-125-600-16*	595	124	234	5,0
CAP-F-N-125-625-16*	620	124	234	5,0
CAP-F-N-160-600-16*	595	159	244	4,5
CAP-F-N-160-625-16*	620	159	244	5,0
CAP-F-N-200-600-25*	595	199	279	4,5
CAP-F-N-200-625-25*	620	199	279	4,5
CAP-F-N-250-600-49*	595	249	334	4,5
CAP-F-N-250-625-49*	620	249	334	4,5
CAP-F-N-315-600-64*	595	314	384	4,0
CAP-F-N-315-625-64*	620	314	384	4,0
CAP-F-N-400-600-81*	595	399	485	4,0
CAP-F-N-400-625-81*	620	399	485	4,0

NOTE: \* Number of nozzles

# Ordering Codes

## Nominal size (connection diameter)

125

160

200

250

315

400

## T-bar raster size

600

625

## Number of nozzles

**16** (for nom. size 125)

**25** (for nom. size 160)

**36** (for nom. size 200)

**49** (for nom. size 250)

**81** (for nom. size 315)

**81** (for nom. size 400)

## Surface and nozzle colour

**SW** Signal white (RAL9003, gloss 30%)

## Example of the Ordering Code

**CAP-F-N-250-600-49-SW**

Diffuser CAP-F-N in signal white colour (RAL 9003) with connection diameter 250 mm and 49 nozzles for T-bar raster 600 mm.

# Accessories

## THOR-F

Plenum Box

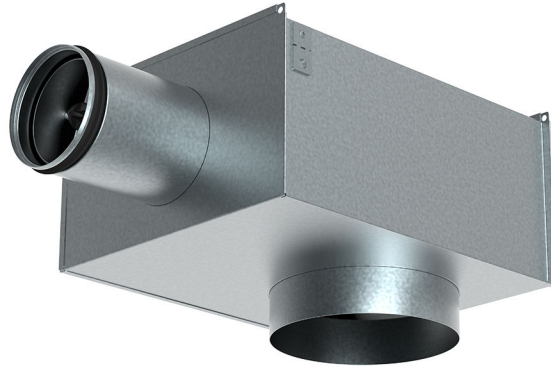

### Description

The THOR-F plenum box is used together with air diffusers for pressure reduction, airflow balancing and sound attenuation as well as for measuring and adjusting the air flow. The plenum box can be used for air inlet and extract.

### Design

THOR-F plenum boxes are manufactured from hot-dip galvanized sheet steel with inlet connection sleeve fitted with a rubber seal tested for air-tightness. The inlet is equipped by the damper with impulse tubes for measuring differential pressure for flow volume calculation, using a portable measuring device. It can be adjusted manually using a cable gearing.



## Dimensions

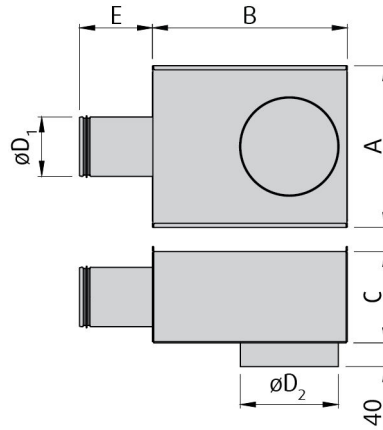

	$DN_1 - DN_2$	A	B	C	$\varnothing D_1$	$\varnothing D_2$	E	m
	mm							kg
THOR-F-	100-125	267	320	150	98	125	135	2,5
	100-160					160		
	125-200					200	150	
	160-250	317	450	195	158	250	165	4,0
	200-315	367	500	250	198	315	175	5,2
	250-400	467	565	300	248	400	190	7,2
	315-400	567	620	400	313		205	10,4

## Ordering Codes

Nominal size: Inlet-Outlet

100-125

100-160

125-200

160-250

200-315

250-400

315-400

Example of the Ordering Code

THOR-F-100-160

Plenum box THOR-F with 100 mm circular inlet and 160 mm circular outlet (nominal dimensions).

# Quick Selection

Air flow volume  $q_v$  at different A-weighted sound power levels  $L_{WA}$

	25 dB(A)		30 dB(A)		35 dB(A)	
	m <sup>3</sup> /h	l/s	m <sup>3</sup> /h	l/s	m <sup>3</sup> /h	l/s
CAP-F-N-125-16	67	19	86	24	106	29
CAP-F-N-160-16	79	22	100	28	125	35
CAP-F-N-200-25	107	30	137	38	169	47
CAP-F-N-250-49	198	55	251	70	304	84
CAP-F-N-315-64	283	79	351	98	428	119
CAP-F-N-400-81	436	121	552	153	666	185

Air flow volume  $q_v$  at different A-weighted sound pressure levels  $L_{pA}$  with 10m<sup>2</sup> absorption area

	25 dB(A)		30 dB(A)		35 dB(A)	
	m <sup>3</sup> /h	l/s	m <sup>3</sup> /h	l/s	m <sup>3</sup> /h	l/s
CAP-F-N-125-16	82	23	101	28	125	35
CAP-F-N-160-16	94	26	119	33	147	41
CAP-F-N-200-25	131	36	162	45	202	56
CAP-F-N-250-49	238	66	293	81	355	99
CAP-F-N-315-64	334	93	409	114	488	136
CAP-F-N-400-81	529	147	642	178	766	213

NOTE: The working points were measured with THOR-F plenum box and open adjustment damper.

For CAP-F-N-400-81 was used with plenum box THOR-F-315-400.

# Technical Parameters

## Legends

$P_s$	Pa	Pressure drop
$q_v$	m <sup>3</sup> /h, l/s	Air flow volume
$L_{WA}$	dB(A)	A-weighted total radiated sound power level
$L_{pA}$	dB(A)	A-weighted total sound pressure level expressed for 10 m <sup>2</sup> room absorption area
$L_W$	dB	Non weighted total sound power level
$L_{0,2}$	m	Air throw length with terminal velocity 0,2 m/s
$L_x$	m	Air throw length calculated for specific terminal velocity
$X$	(m/s)	Terminal velocity in range of 0,1 m/s ... 1 m/s
20%, 40%, 60%,80%, 100%		The plenum box damper positions in pressure drop/noise diagrams are represented as percentage. 20% is fully closed damper. 100% is fully open damper.

Calculation of Air Throw for Different Terminal Velocities

$$L_x = L_{0,2} \cdot 0,2/x$$

Pressure drop & A-weighted total sound power level, depending on air flow volume

**CAP-F-N-125-600-16-SW + THOR-F-100-125**

Pressure drop & sound power level (A-weighted)

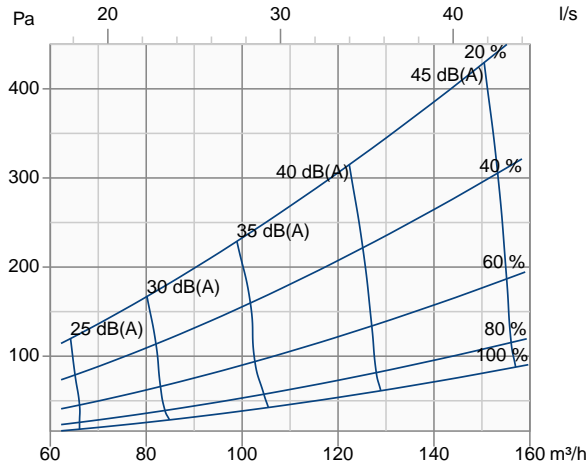

**CAP-F-N-160-600-16-SW + THOR-F-100-160**

Pressure drop & sound power level (A-weighted)

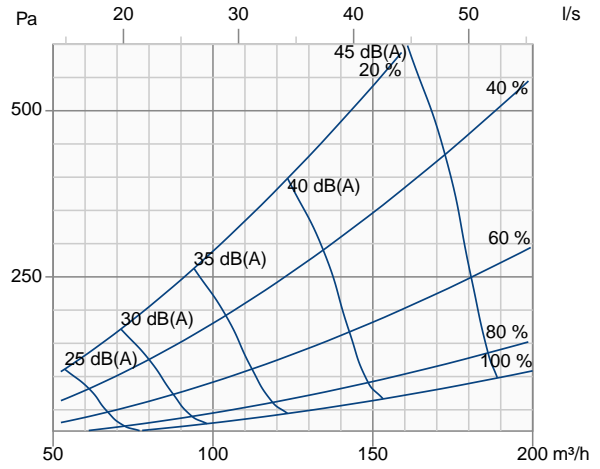

**CAP-F-N-125-600-16-SW + THOR-F-100-125**

Throw length (terminal velocity 0.2 m/s)

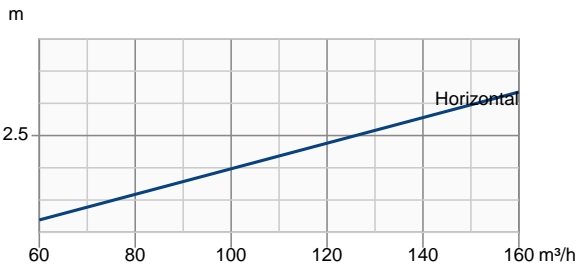

**CAP-F-N-160-600-16-SW + THOR-F-100-160**

Throw length (terminal velocity 0.2 m/s)

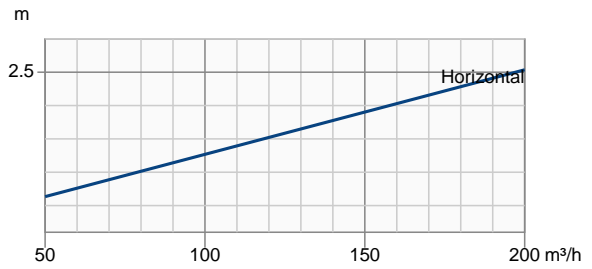

**CAP-F-N-200-600-25-SW + THOR-F-125-200**

Pressure drop & sound power level (A-weighted)

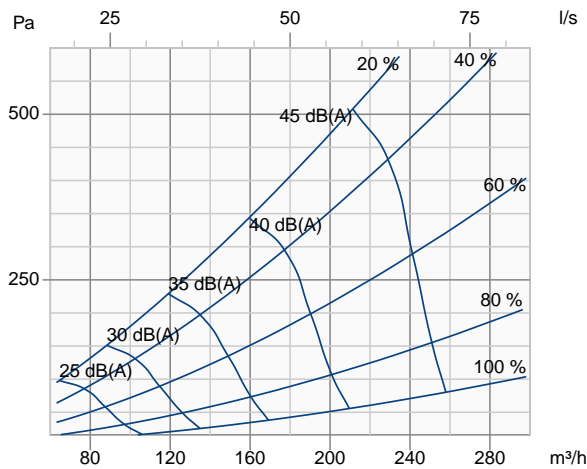

**CAP-F-N-250-600-49-SW + THOR-F-160-250**

Pressure drop & sound power level (A-weighted)

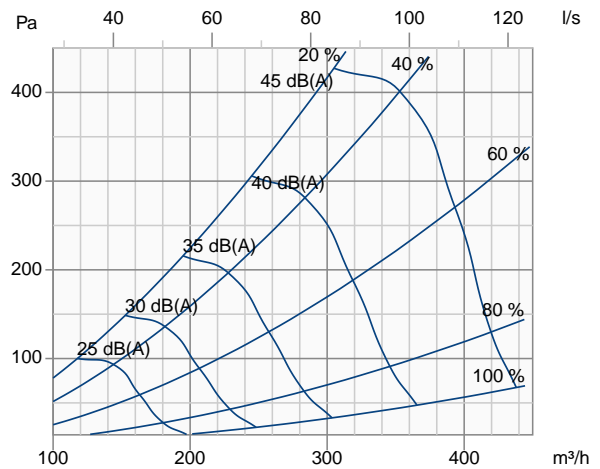

**CAP-F-N-200-600-25-SW + THOR-F-125-200**

Throw length (terminal velocity 0.2 m/s)

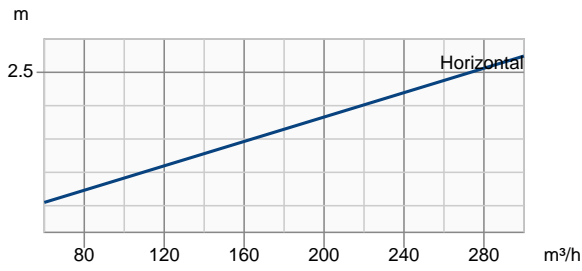

**CAP-F-N-250-600-49-SW + THOR-F-160-250**

Throw length (terminal velocity 0.2 m/s)

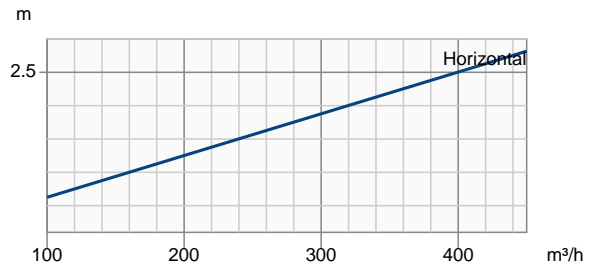

**CAP-F-N-315-600-64-SW + THOR-F-200-315**

Pressure drop & sound power level (A-weighted)

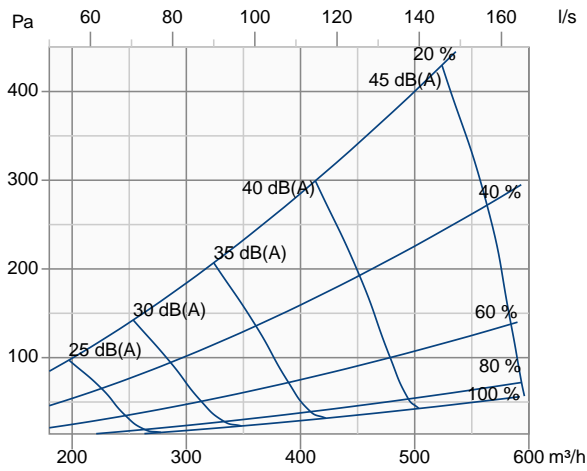

**CAP-F-N-400-600-81-SW + THOR-F-250-400**

Pressure drop & sound power level (A-weighted)

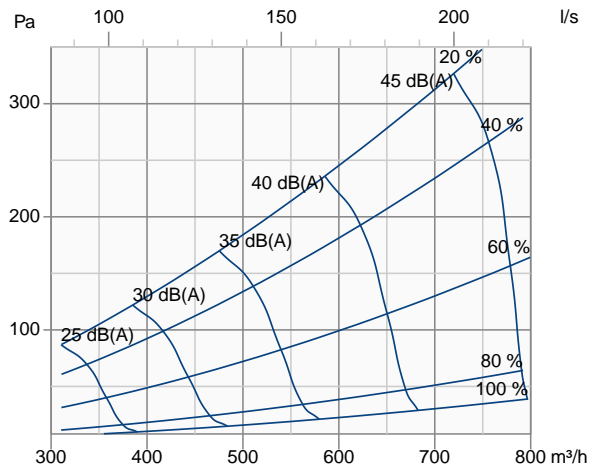

**CAP-F-N-315-600-64-SW + THOR-F-200-315**

Throw length (terminal velocity 0.2 m/s)

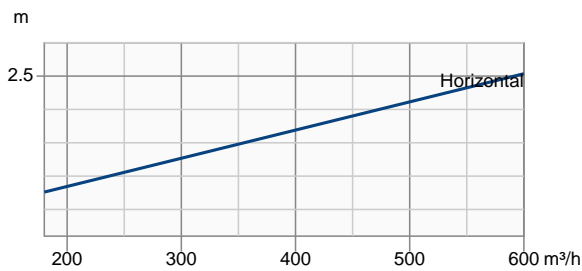

**CAP-F-N-400-600-81-SW + THOR-F-250-400**

Throw length (terminal velocity 0.2 m/s)

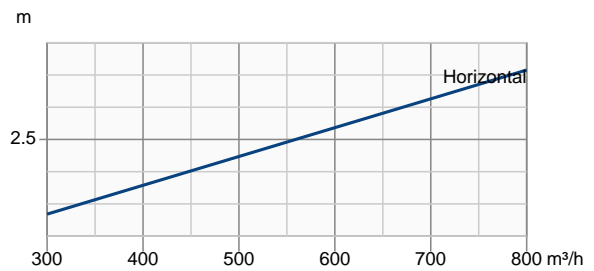

CAP-F-N-400-600-81-SW + THOR-F-315-400

Pressure drop & sound power level (A-weighted)

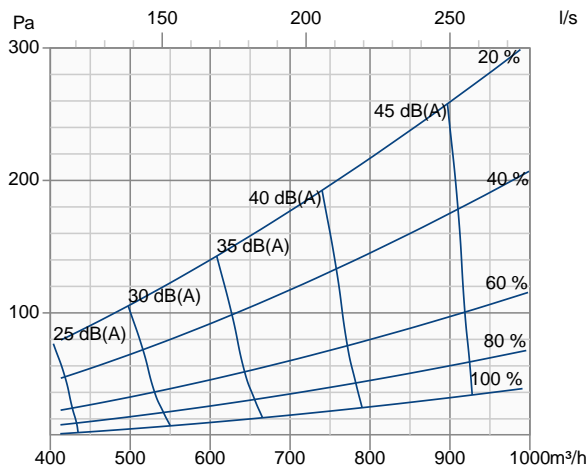

CAP-F-N-400-600-81-SW + THOR-F-315-400

Throw length (terminal velocity 0.2 m/s)

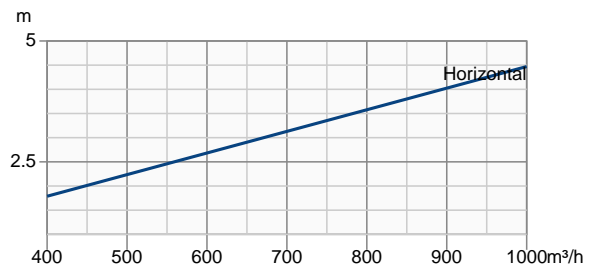

Pressure drop & A-weighted total sound power level, depending on air flow volume, measured without THOR-F plenum box

**CAP-F-N-125-600-16-SW**

Pressure drop & sound power level (A-weighted)

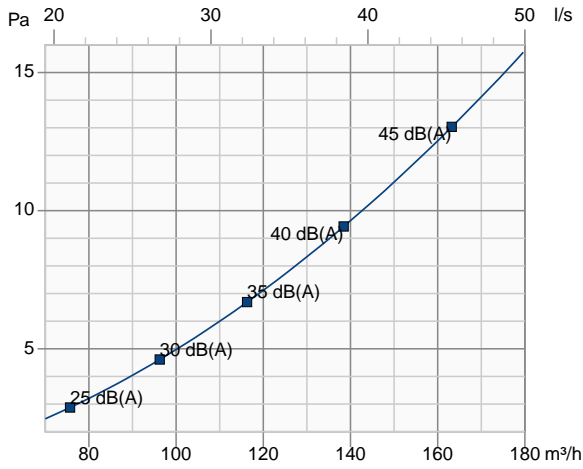

**CAP-F-N-160-600-16-SW**

Pressure drop & sound power level (A-weighted)

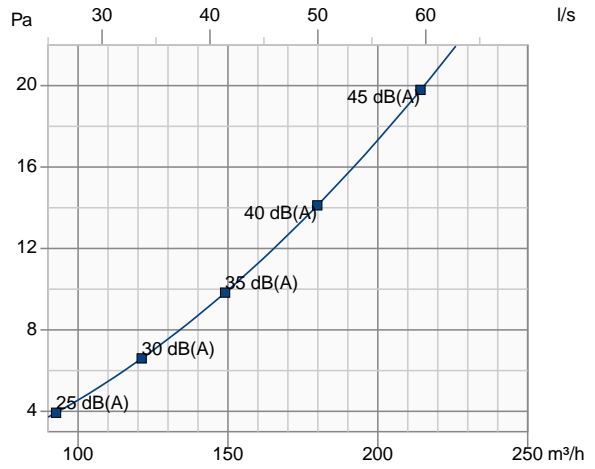

**CAP-F-N-125-600-16-SW**

Throw length (terminal velocity 0.2 m/s)

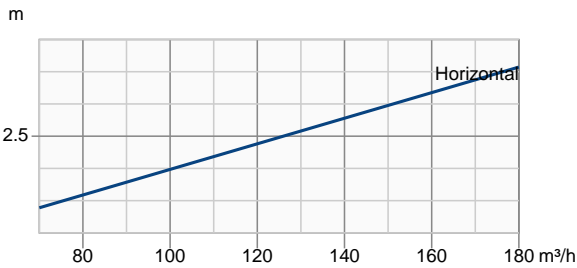

**CAP-F-N-160-600-16-SW**

Throw length (terminal velocity 0.2 m/s)

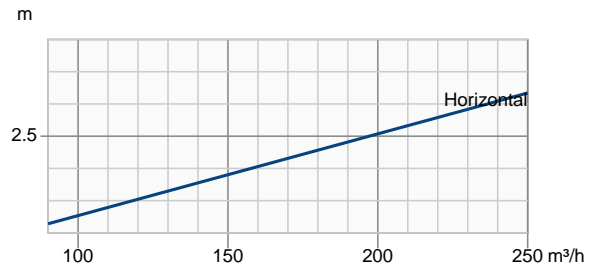

**CAP-F-N-200-600-25-SW**

Pressure drop & sound power level (A-weighted)

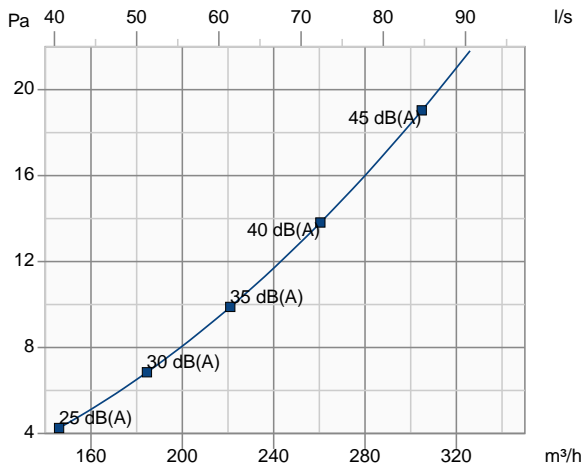

**CAP-F-N-250-600-49-SW**

Pressure drop & sound power level (A-weighted)

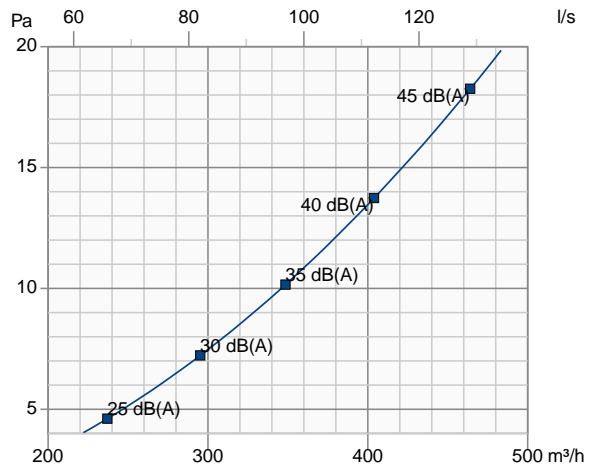

**CAP-F-N-200-600-25-SW**

Throw length (terminal velocity 0.2 m/s)

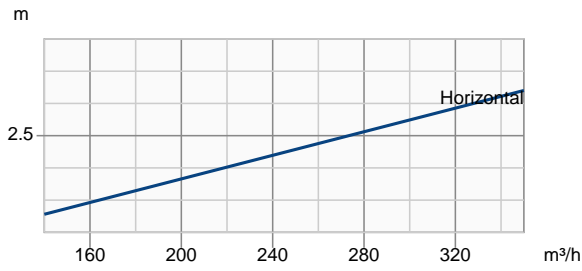

**CAP-F-N-250-600-49-SW**

Throw length (terminal velocity 0.2 m/s)

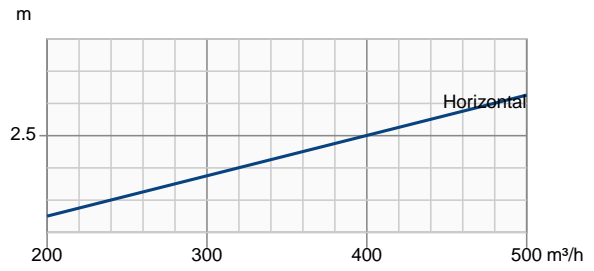

**CAP-F-N-315-600-64-SW**

Pressure drop & sound power level (A-weighted)

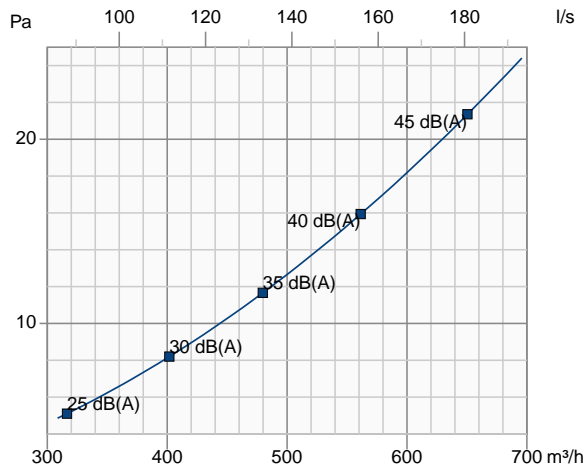

**CAP-F-N-400-600-81-SW**

Pressure drop & sound power level (A-weighted)

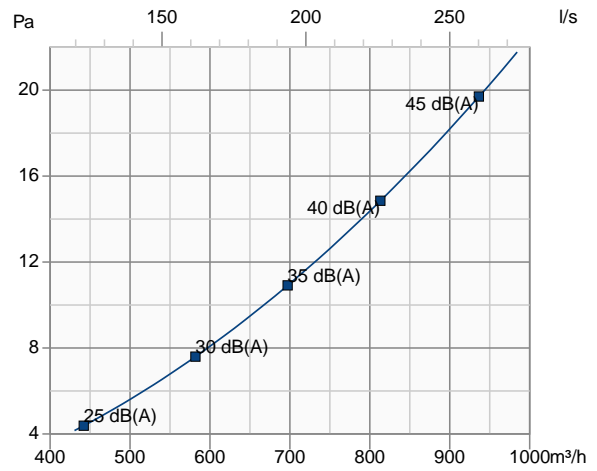

**CAP-F-N-315-600-64-SW**

Throw length (terminal velocity 0.2 m/s)

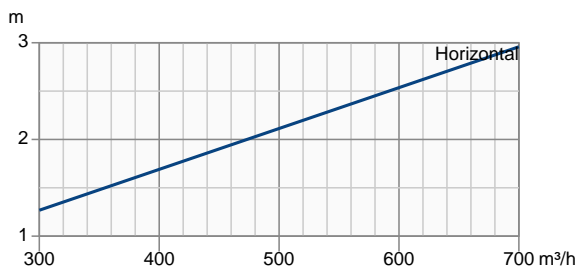

**CAP-F-N-400-600-81-SW**

Throw length (terminal velocity 0.2 m/s)

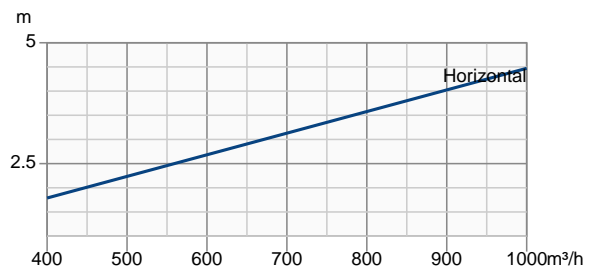



# Installation

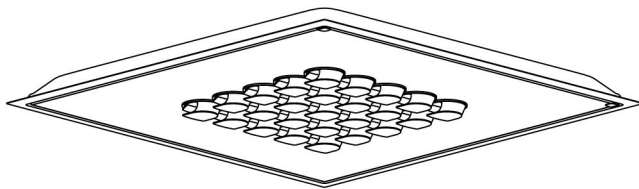
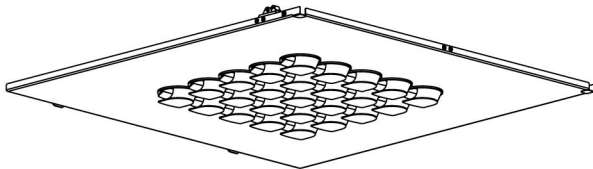
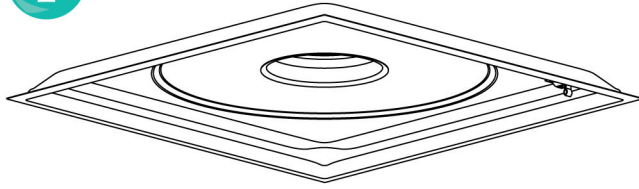

"CAP-F-N"

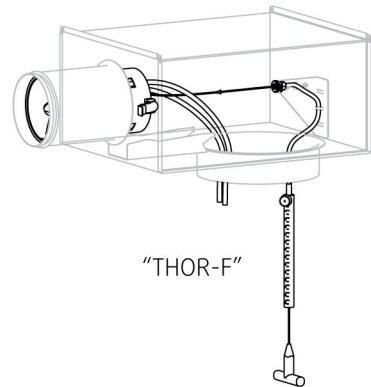
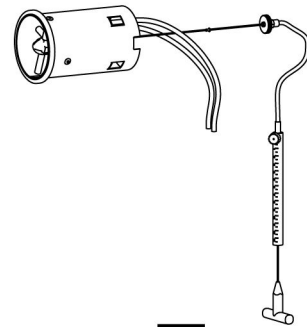
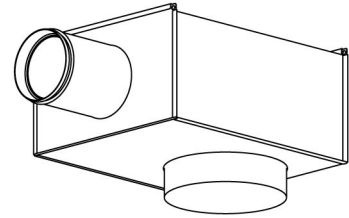

"THOR-F"

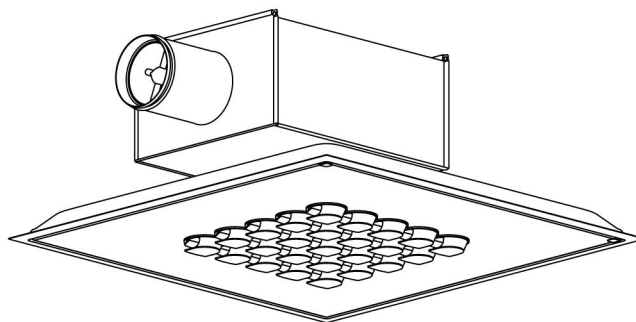

"CAP-F-N" + "THOR-F"

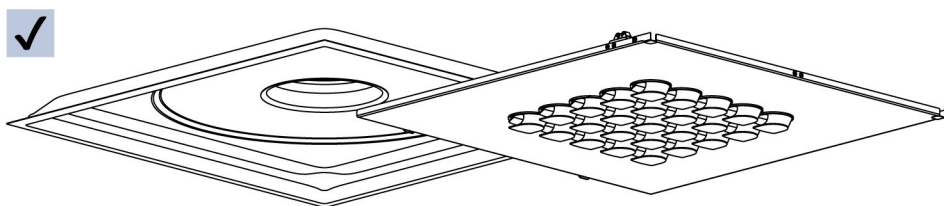
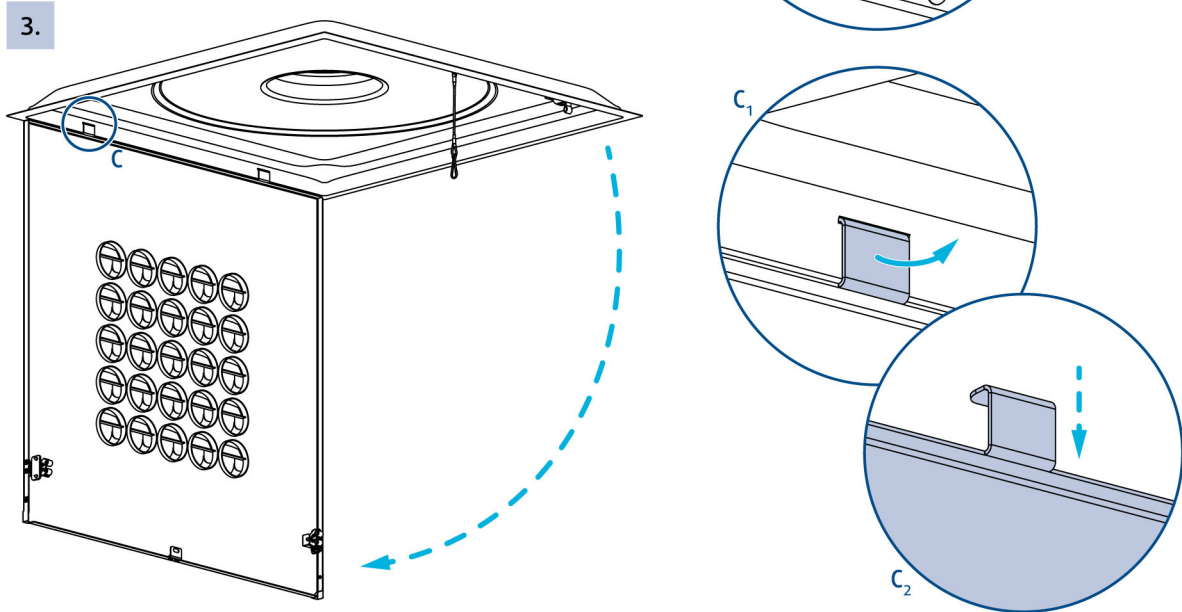
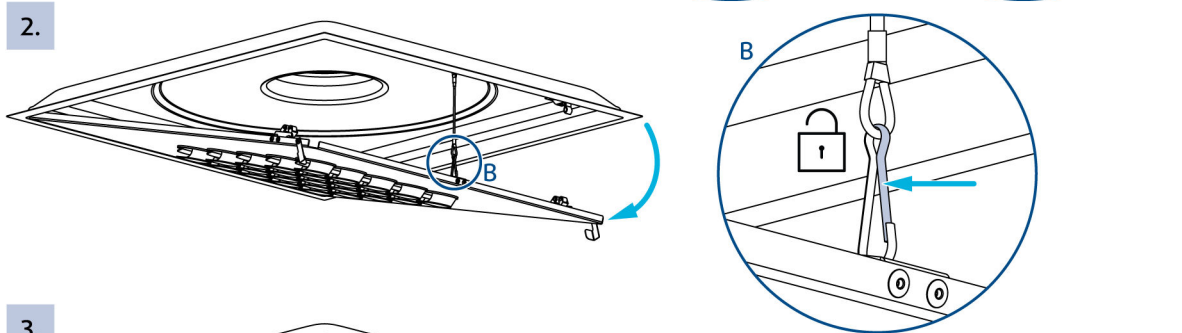
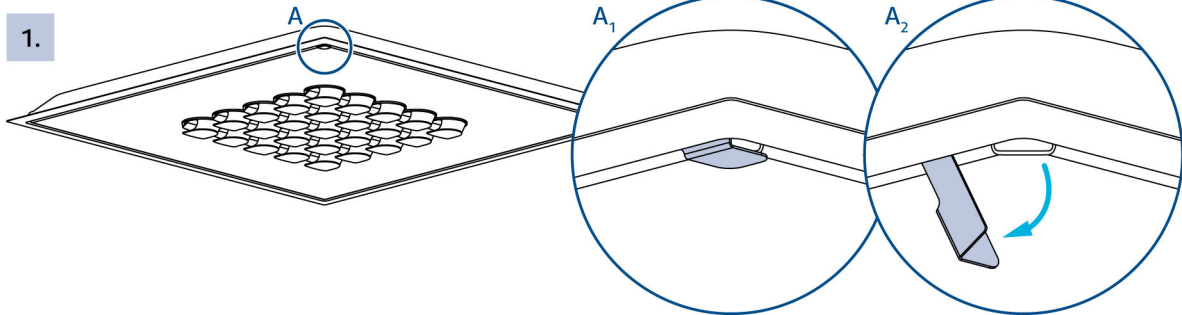
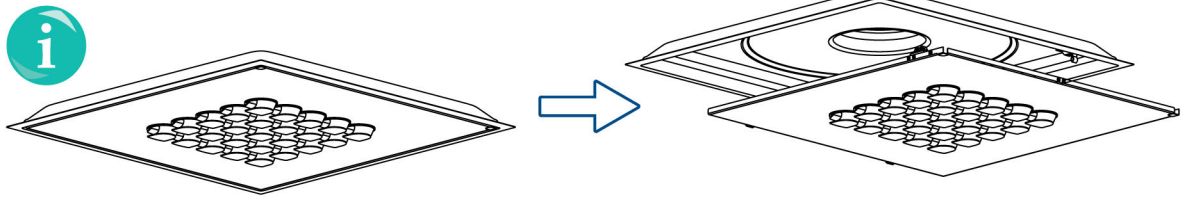

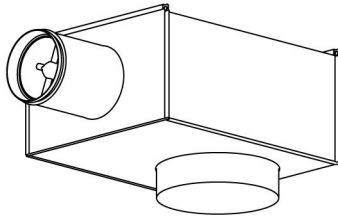

4.  $1 \times D / 3 \times E$

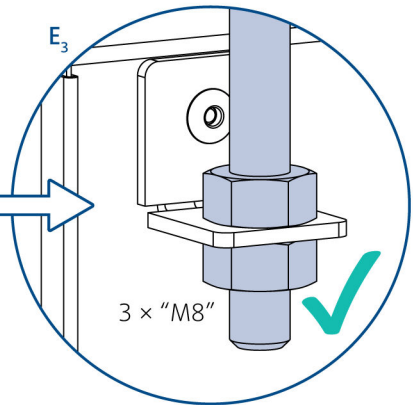
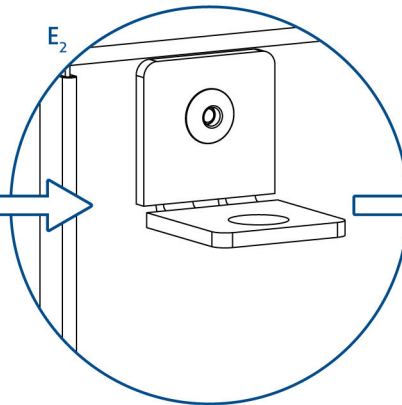
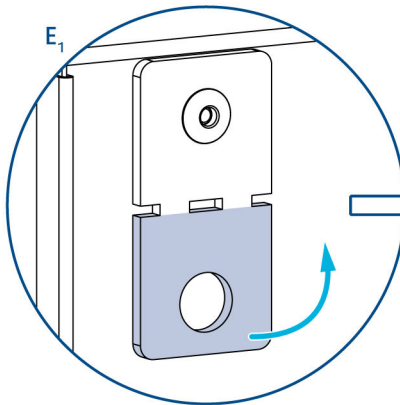
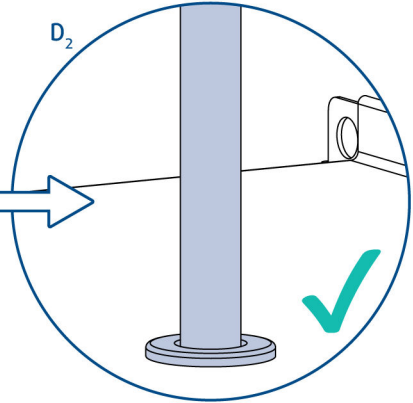
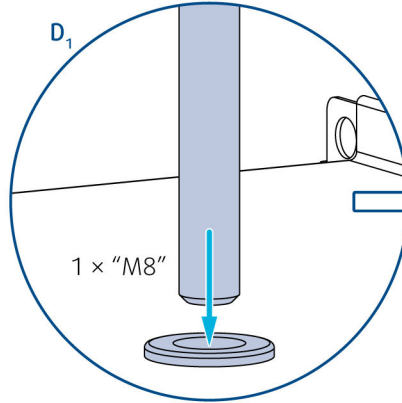
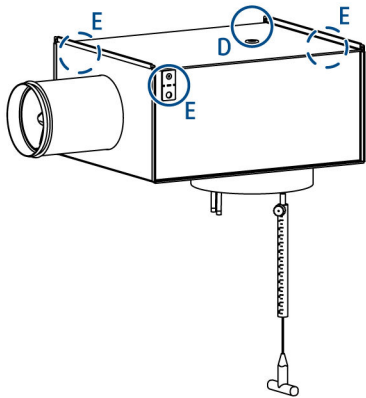

5.

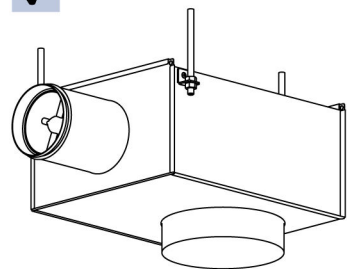
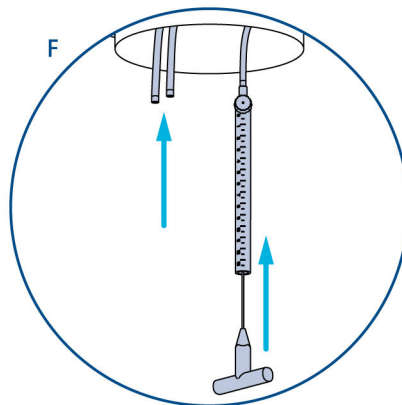
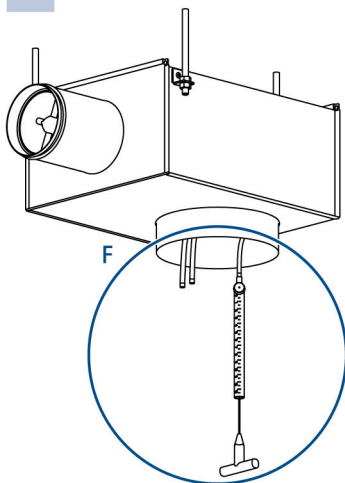

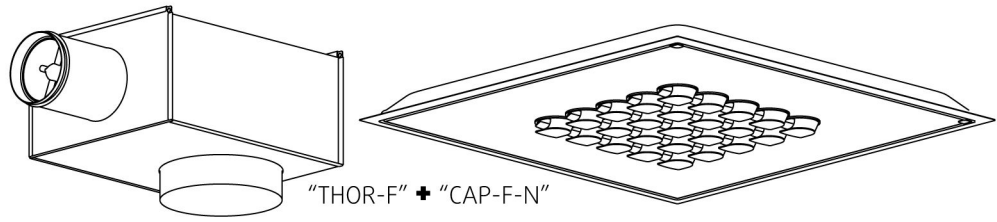

"THOR-F" + "CAP-F-N"

6.

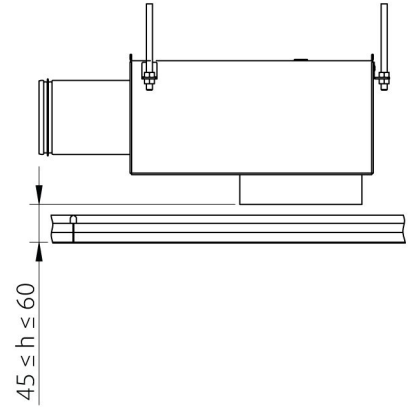
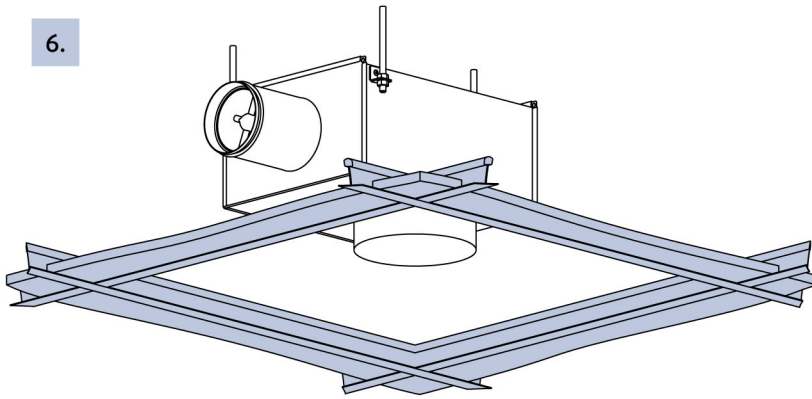

7.

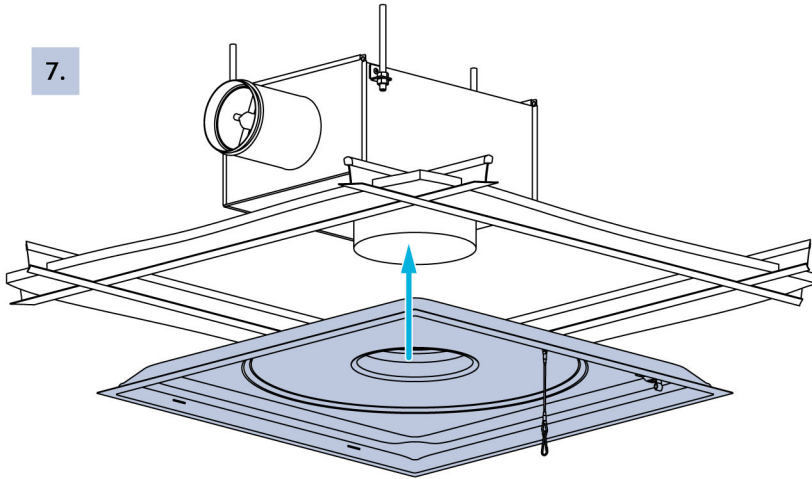

8.

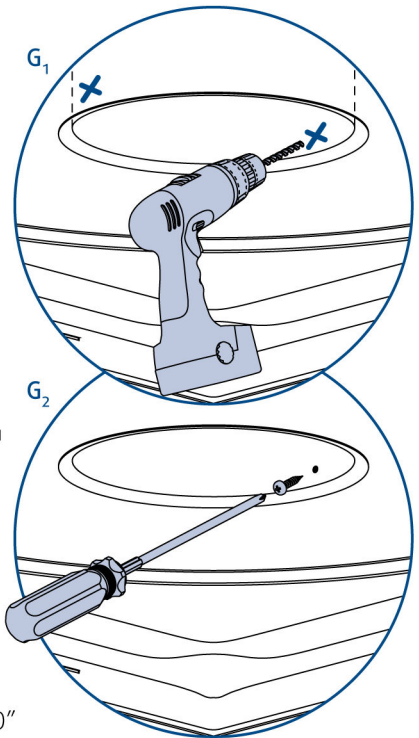
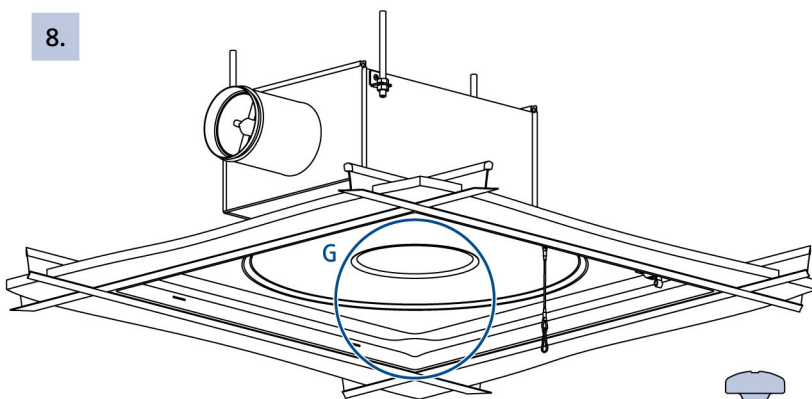

2 x "ø4x10"

9.

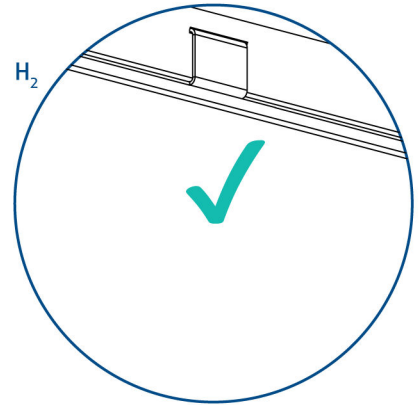
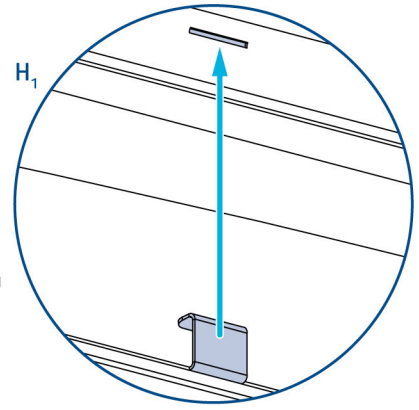
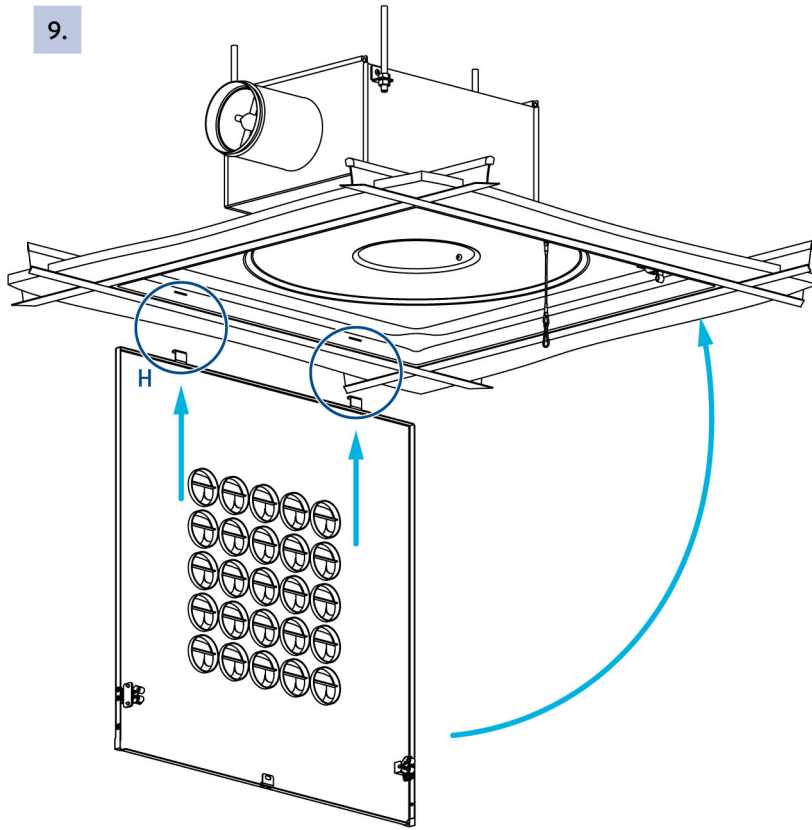

10.

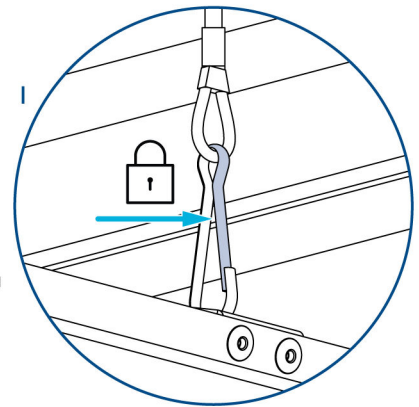
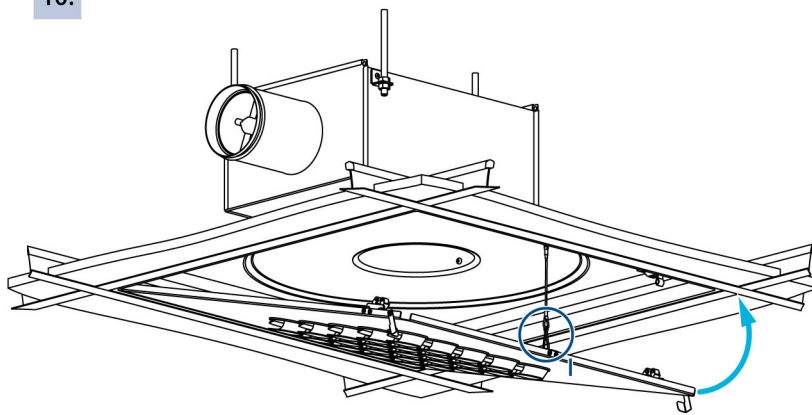

✓

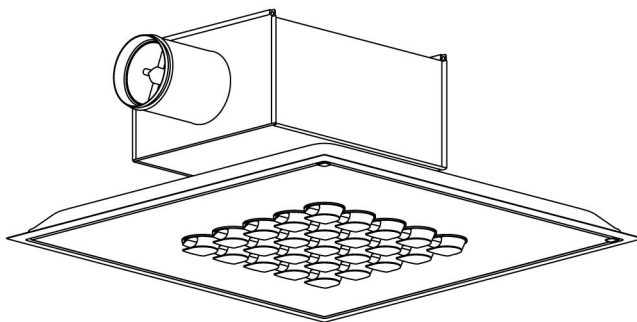

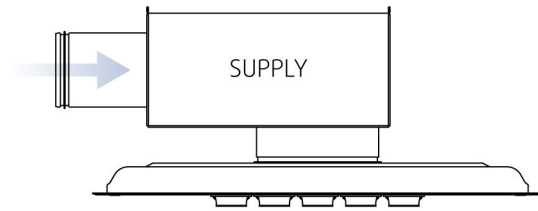

11. = 1.

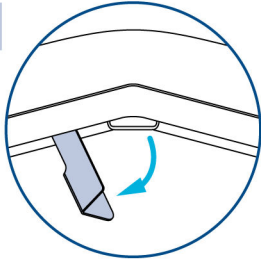

12. = 2.

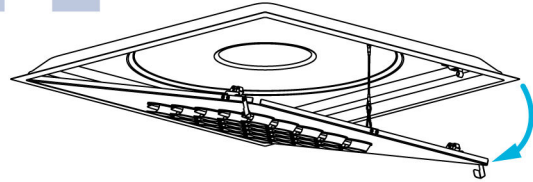

13.

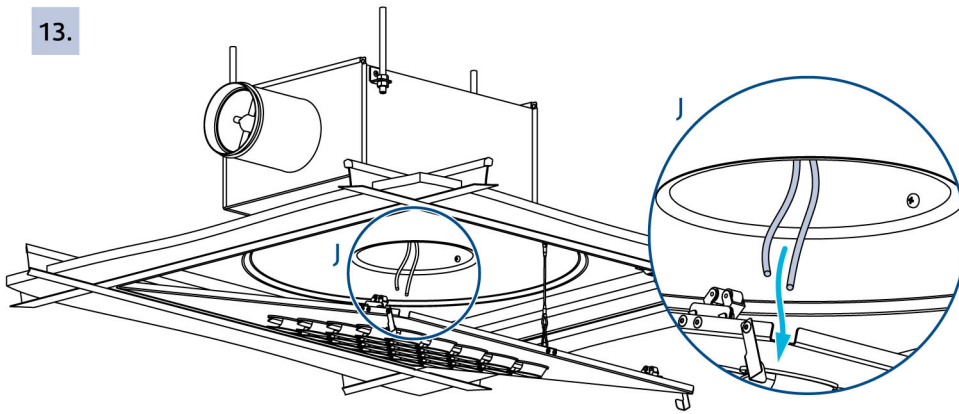

14. = 10.

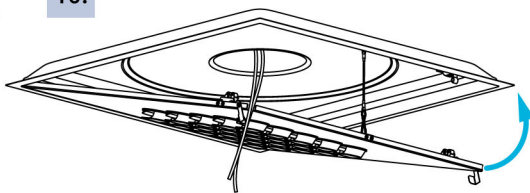

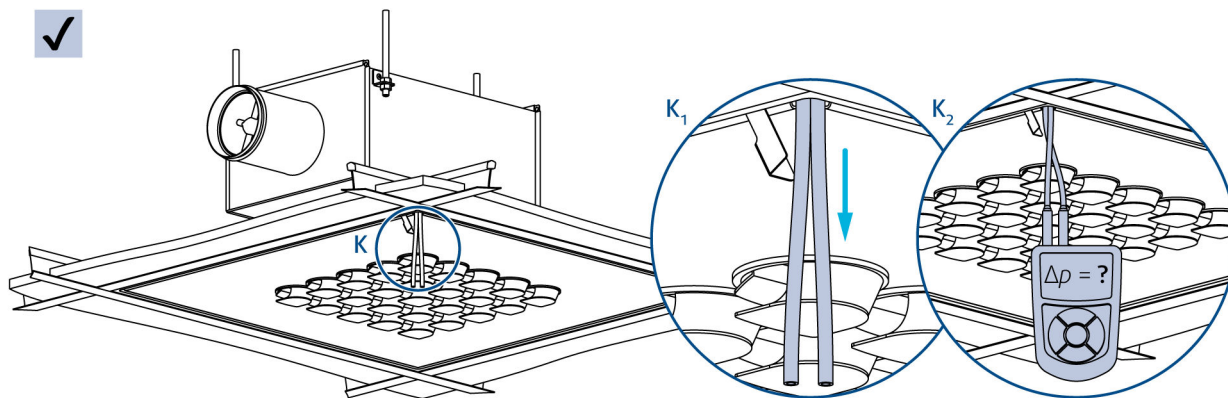

$$q = k \sqrt{\Delta p} \text{ (Pa)}$$

		$k \rightarrow q \text{ (m}^3/\text{h)}$	$k \rightarrow q \text{ (l/s)}$
CAP-F-N-125-16	THOR-F-100-125	15,7	4,4
CAP-F-N-160-16	THOR-F-100-160		
CAP-F-N-200-25	THOR-F-125-200	29,1	8,1
CAP-F-N-250-49	THOR-F-160-250	52,6	14,6
CAP-F-N-315-64	THOR-F-200-315	82,6	22,9
CAP-F-N-400-81	THOR-F-250-400	134,4	37,3
CAP-F-N-400-81	THOR-F-315-400	226,2	62,8



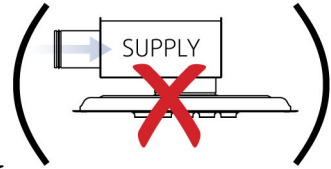
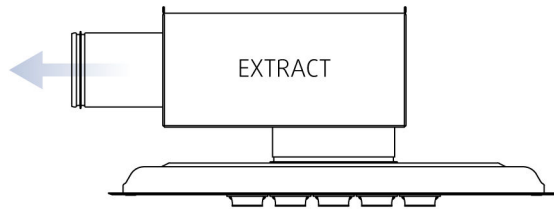

15.

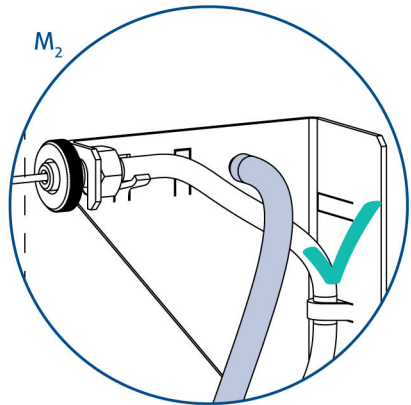
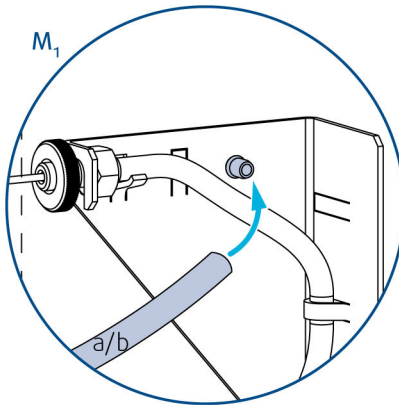
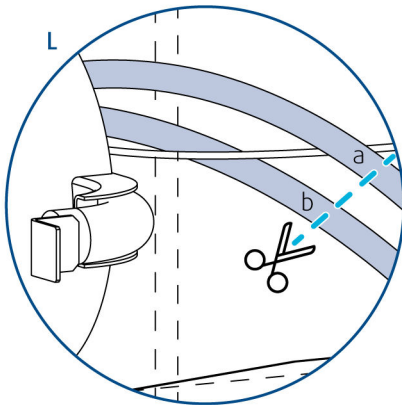
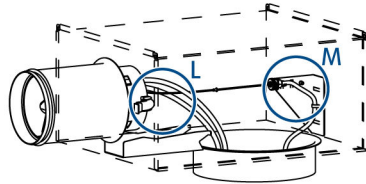

16. = 1.

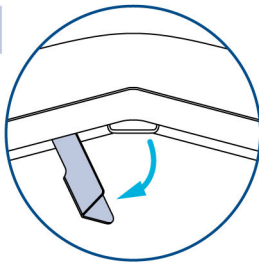

17. = 2.

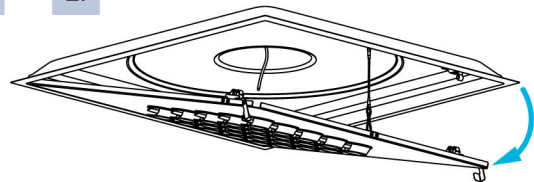

18.

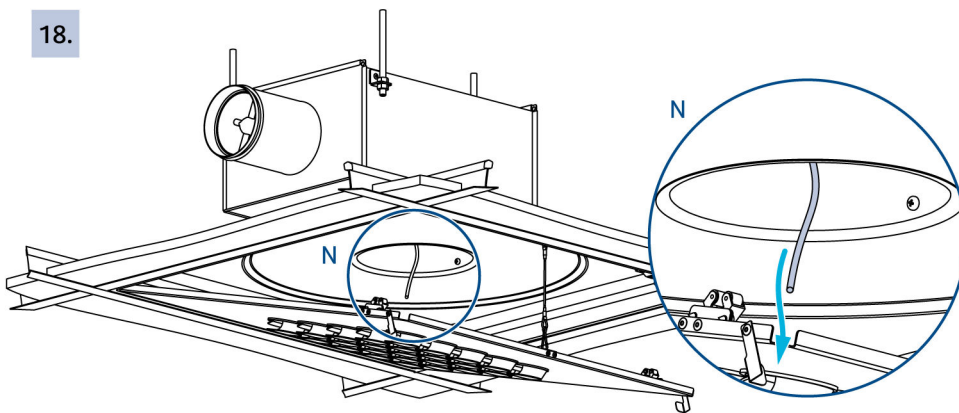



19. = 10.

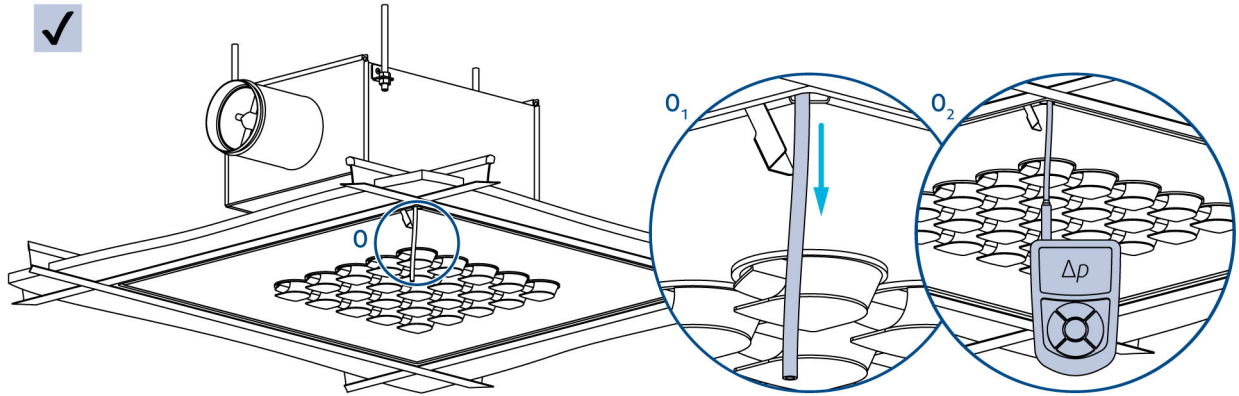
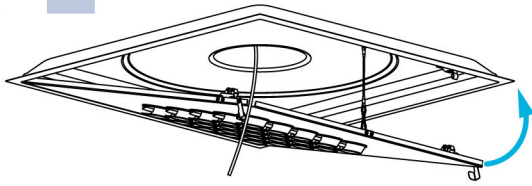

$$q = k \sqrt{\Delta p} \text{ (Pa)}$$

		$k \rightarrow q \text{ (m}^3/\text{h)}$	$k \rightarrow q \text{ (l/s)}$
CAP-F-N-125-16	THOR-F-100-125	33,1	9,2
CAP-F-N-160-16	THOR-F-100-160	40,4	11,2
CAP-F-N-200-25	THOR-F-125-200	57,8	16,1
CAP-F-N-250-49	THOR-F-160-250	105,3	29,2
CAP-F-N-315-64	THOR-F-200-315	138,2	38,4
CAP-F-N-400-81	THOR-F-250-400	181,7	50,5
CAP-F-N-400-81	THOR-F-315-400		

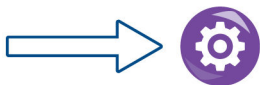

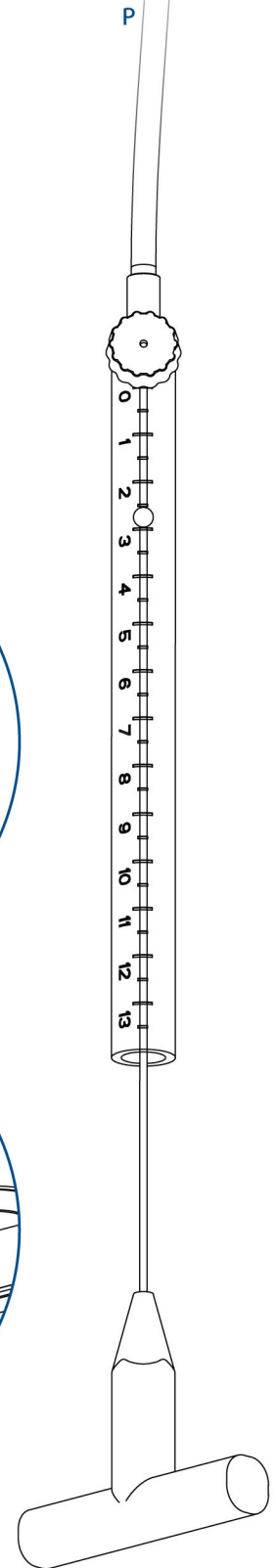
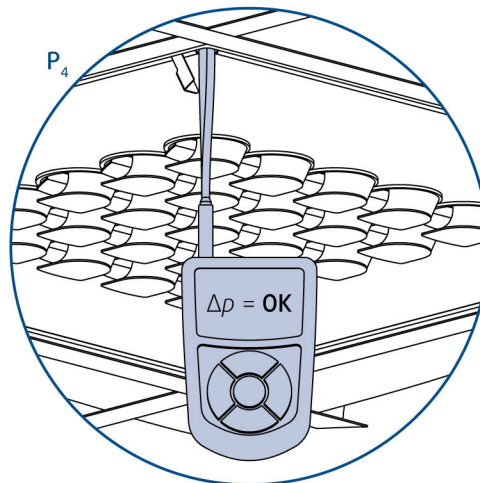
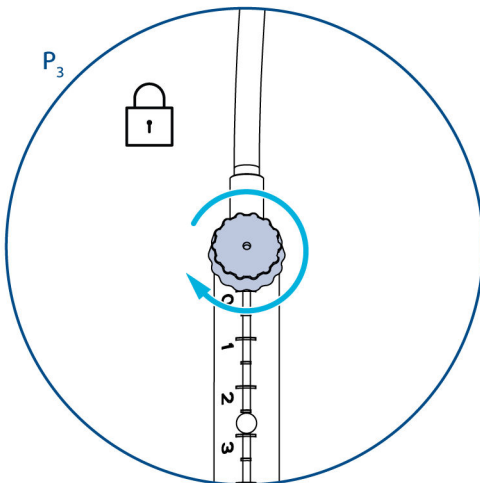
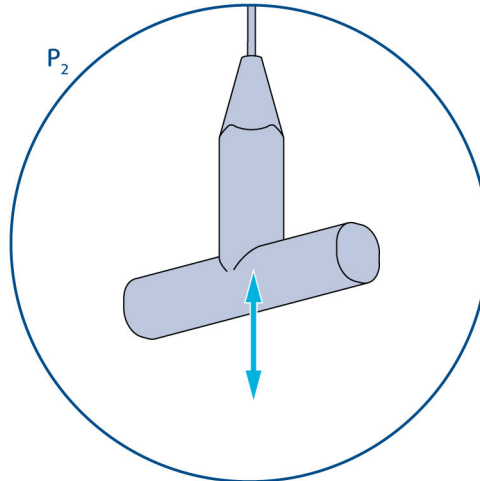
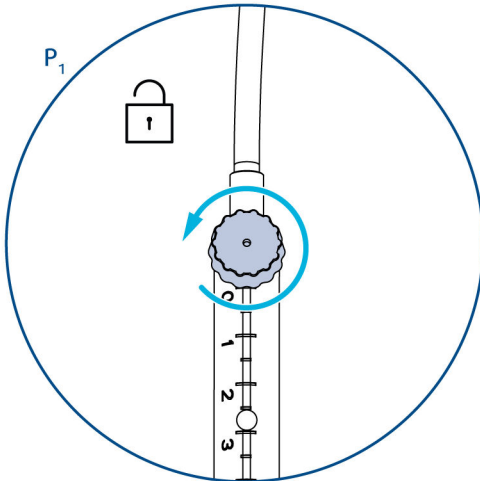
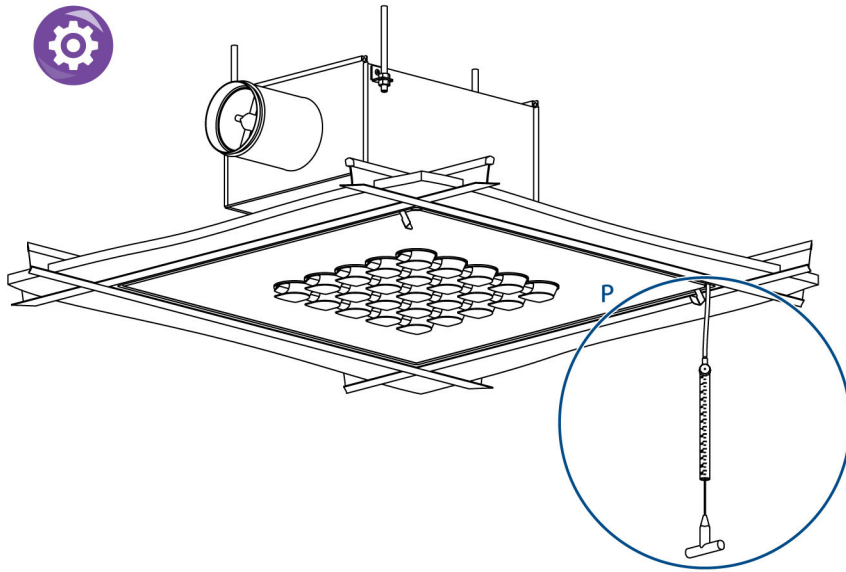

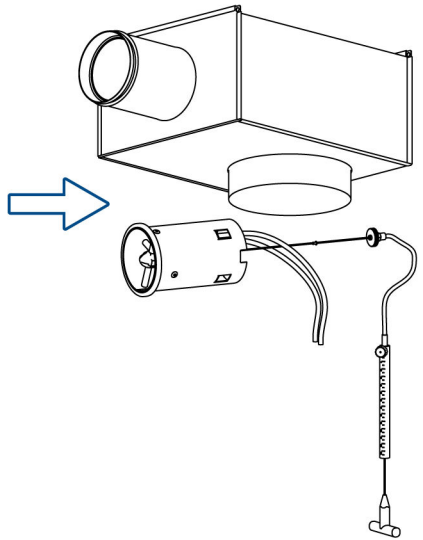
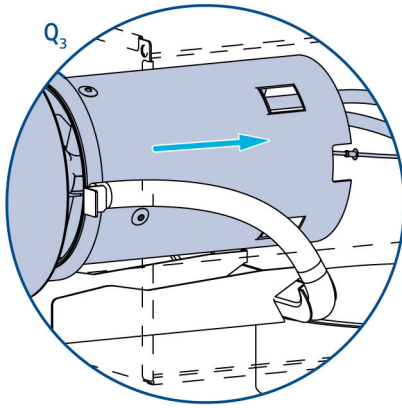
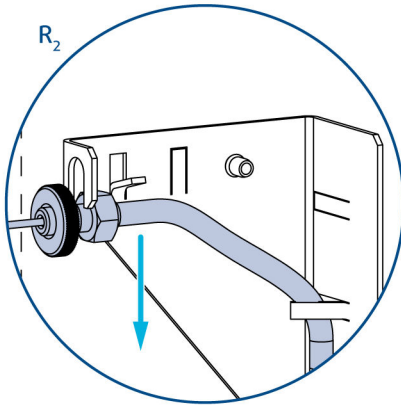
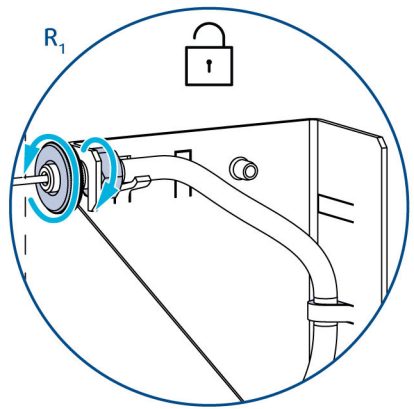
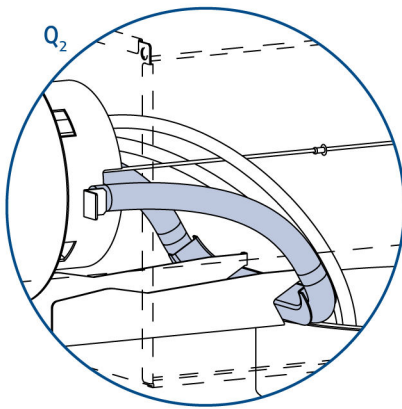
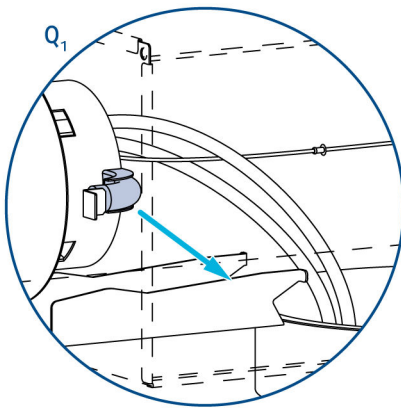
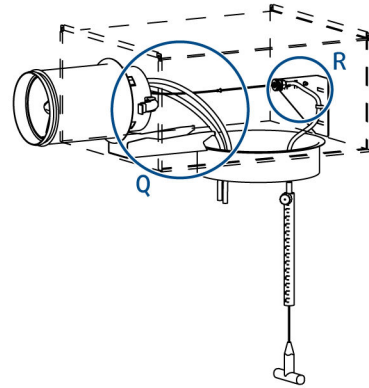
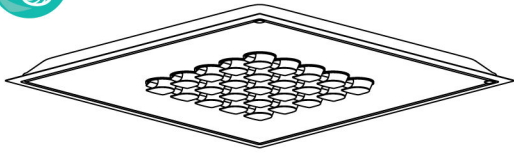

# Transport, Storage and Operation

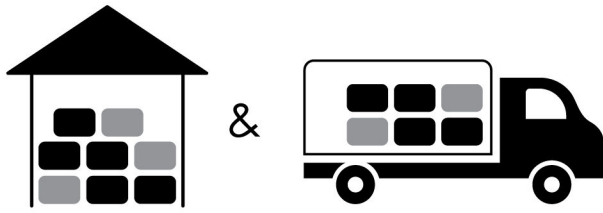

 °C -40°C ... +50°C

 % ≤ 95%



 °C -20°C ... +50°C

 % ≤ 95%

# Supplement

Any deviations from the technical specifications contained herein and the terms should be discussed with the manufacturer. We reserve the right to make any changes to the product without prior notice, provided that these changes do not affect the quality of the product and the required parameters.

Current information on all products is available on [design.systemair.com](https://design.systemair.com).

